

Maximum capacity 440 kg, up to 8 meters in height

DUE SICUREZZE INDIPENDENTI

- ▶ Braked winch
- ▶ Automatic anti-fall device

STRUCTURE

- On site in seconds
- Compact and very robust construction
- Variable width forks
- Two Ø200 mm wheels for easy transport on site
- Base with 2 stabilizing arms
- Feet with adjustable wheels
- Anti-corrosion steel lifting cable
- Level control for perfect positioning
- Winch with automatic brake
- Steel sliding pulleys
- German TÜV-GS-BGVD8 certification
- For facade work
- Motorizable



SOLLEVATORE		TORO-D 401	TORO-D 402/C	TORO-D 403/C	TORO-D 404	TORO-D 405/C	TORO-D 406	TORO-D 407
Load capacity	kg	440	420	400	420	350	400	350
Height	mt.	1,99	1,61	1,61	1,99	1,61	1,99	1,99
Fork loading height	mt.	3,55	3,85	5,00	5,00	6,00	6,50	8,00
Weight	kg	160	157	175	173	191	190	219



Toro D manual fork lift

Technical features

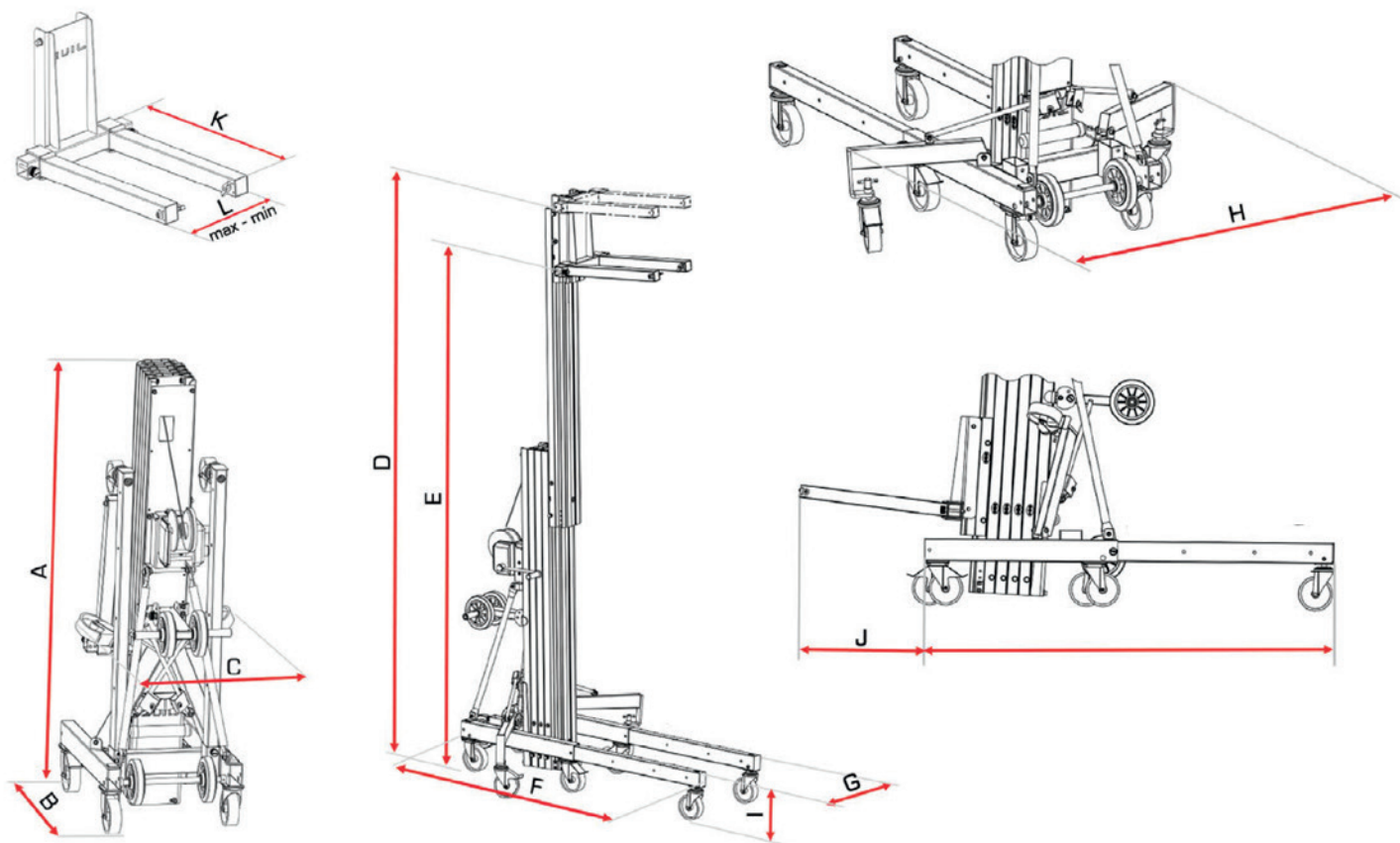

		A	B	C	D	E	F	G	H	I	J	K	L	M	N
Model	Range	cm.	cm.	cm.	cm.	cm.	cm.	cm.	cm.	cm.	cm.	cm.	cm.	cm.	cm.
D-401	440 kg	199	95	66	355	315	192	66	147	28	57	66	47,5 max 35,5 min	33	183
D-402/C	420 kg	161	95	66	385	345	192	66	147	28	57	66	47,5 max 35,5 min	33	183
D-403/C	400 kg	161	95	66	500	460	192	66	147	28	57	66	47,5 max 35,5 min	33	183
D-404	420 kg	199	95	66	500	460	192	66	147	28	57	66	47,5 max 35,5 min	33	183
D-405/C	350 kg	161	95	66	600	560	192	66	147	28	57	66	47,5 max 35,5 min	33	183
D-406	400 kg	199	95	66	650	610	192	66	147	28	57	66	47,5 max 35,5 min	33	183
D-407	350 kg	199	95	66	800	760	192	66	147	28	57	66	47,5 max 35,5 min	33	183



ACCESSORIES



ACT-01
Support for cylindrical loads



ACT-02
Fork extensions



ACT-04
Loading platform



CW-01/20
Counterweight



CB-01
Basin
Counterweight



**Kit
electric**



ACT-05
Hook



ACT-06
Support for
roller shutters or shutters



ACT-08
Support
with hook



ACT-09
Expander
with forks