

Compact, easily maneuverable and versatile

The perfect solution for any indoor job or to work in skyscrapers all over the world.

TECHNICAL INFORMATION

Dimension	2790 x 770 x 1600 mm
Stab. Area	3700 x 3700 mm

		Kg
Crane & Options Weights		SPX312CP 1800 SPX312C+ 1850
		/
		2T-D7 20
		PP400-4DX 45 PP220-4DX PP220-2DX
		JIB800GX 20 JIB400.1MX 70
		MV600.3E+ 180

SPX312CP	Petrol Engine	YAMAHA MZ 360	7.6 kW 10.4 Hp
SPX312C+	Standard or Lithium Battery	N. 4 BATTERIES 6V, 240Ah	4.0 kW 5.5 Hp

Speed		1.7 km/h
Gradability		20°
Ext. Tracks		770-1060 mm



	4 kW - 3F 400 VAC 50 Hz
	AUX: EU: 2 kW - 1F 220 VAC 50 Hz USA/CANADA: 4 kW - 1F 110 VAC 60 Hz

Max. Track Load	0.44 kg/cm ²
------------------------	-------------------------

Max. Outrigger Load	1850 kg
----------------------------	---------

CRANE OPTIONS

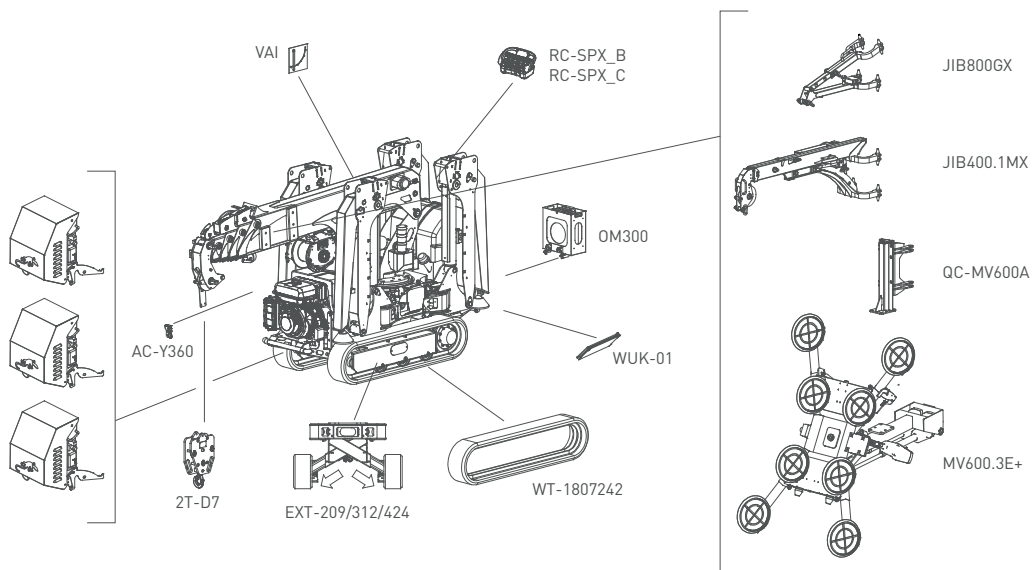

DIMENSIONS

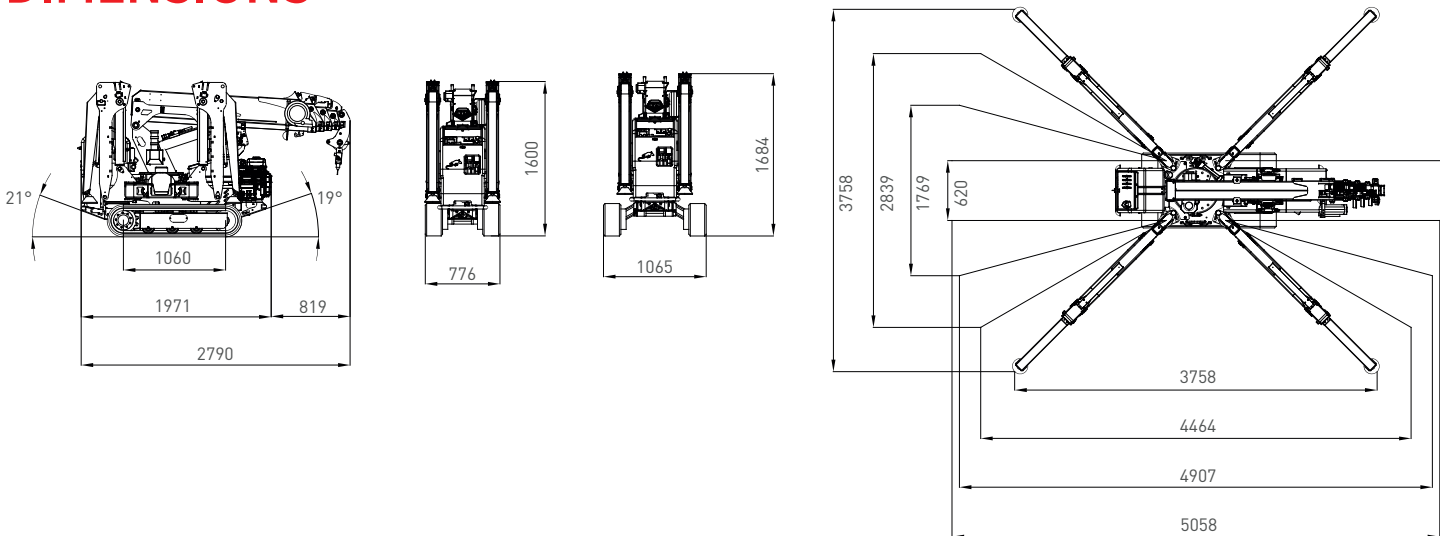

WINCH & FALL STAGES

LOAD CHART

	<p>Main Winch</p> <p>600 kg (Single line)</p> <p>63 m - Ø 7 mm</p> <p>15.1-31.8 m/min.</p>
--	--

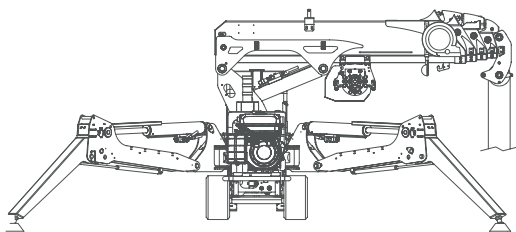

Max. Capacity	Line	Metres
1200 kg	2	-29 m
600 kg	1	-59 m

000 Capacity with jib

